

## CARACTERÍSTICAS TÉCNICAS | Technical Characteristics

MATERIAL Aço e madeira termotratada  
 ACABAMENTO Aço Metalizado e Pintado  
 (Cores Corten ou Antracite, texturados)  
 Madeira com velaturas de protecção e acabamento  
 COLOCAÇÃO Em base rígida  
 PESO APROX. Aprox. 31 Kg

MATERIAL Steel and thermo-treated wood  
 FINISH Tinned and painted steel  
 (Corten/Anthracite textured colors)  
 Wood with protection and finishing varnishing  
 FIXING Set to rigid pavement  
 WEIGHT Approx. 31 Kg

DESIGN Dep. Técnico AMOP

Dimensões (mm)

## DESENHO TÉCNICO | Technical Drawing

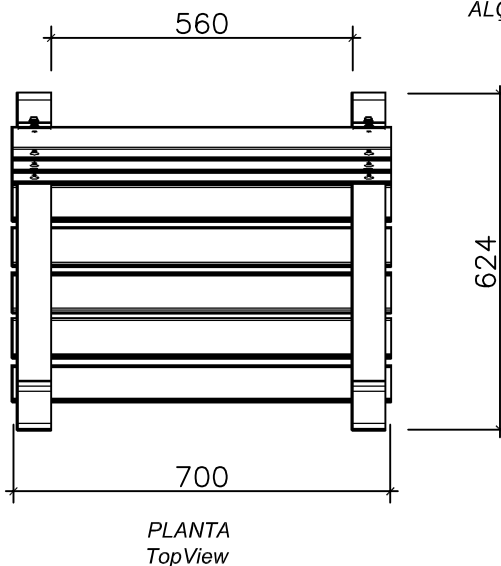
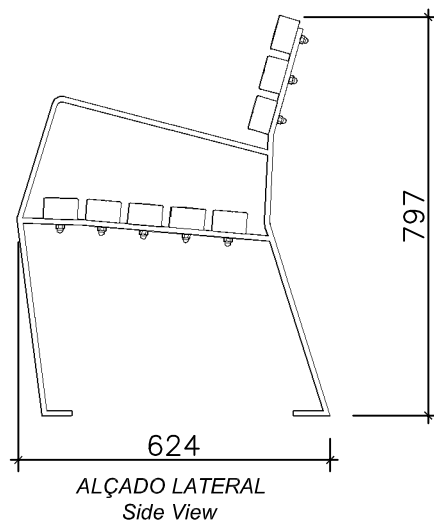
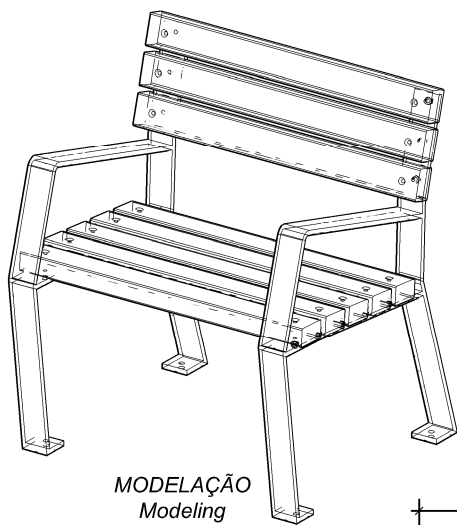

## APLICAÇÃO | Installation

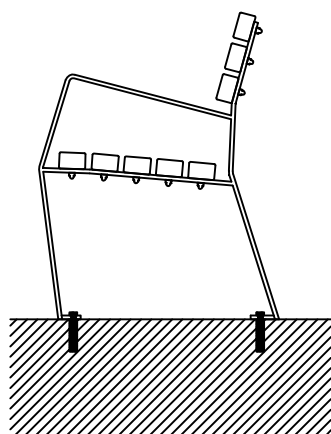

BUCHA METALICA M10 (INCLUIDO)  
 M10 EXPANSION BOLT (INCLUDED)

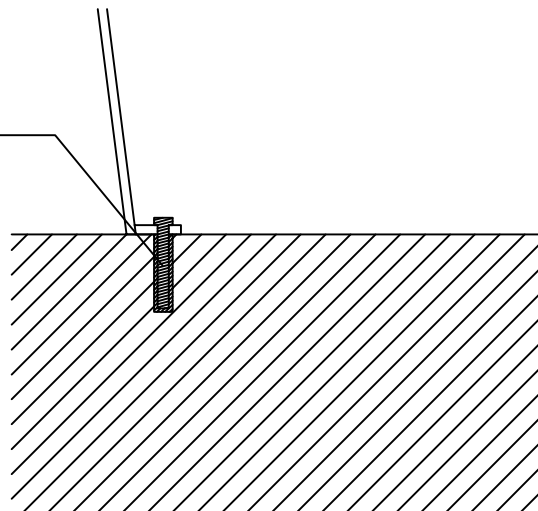

APLICAÇÃO COM 4 BUCHA METALICA M10 (INCLUIDO)  
 INSTALLATION WITH 4 M10 MECHANIC ANCHORS (INCLUDED)

PARAFUSOS PARA MADEIRA EM INOX  
 STAINLESS STEEL WOOD CONNECTION BOLTS

**CADEIRA INDIVIDUAL 2A**

AMP.019/00 EDIÇÃO 0 DATA: 20-05-2011

**ECN2**  
 ECONOMIC TOO

APARTADO 38 3754-906 AGUADA DE BAIXO ÁGUEDA - PORTUGAL  
 TEL 234667957 FAX 234666908  
 ecn2@grupoamop.com www.ecn2.eu

REF.<sup>a</sup> - 13052

FT.13052 Folha | Page 1-1